

(1 : 1)

CLF50-10  
CLF110-10  
CLF220-13  
CLF450-15

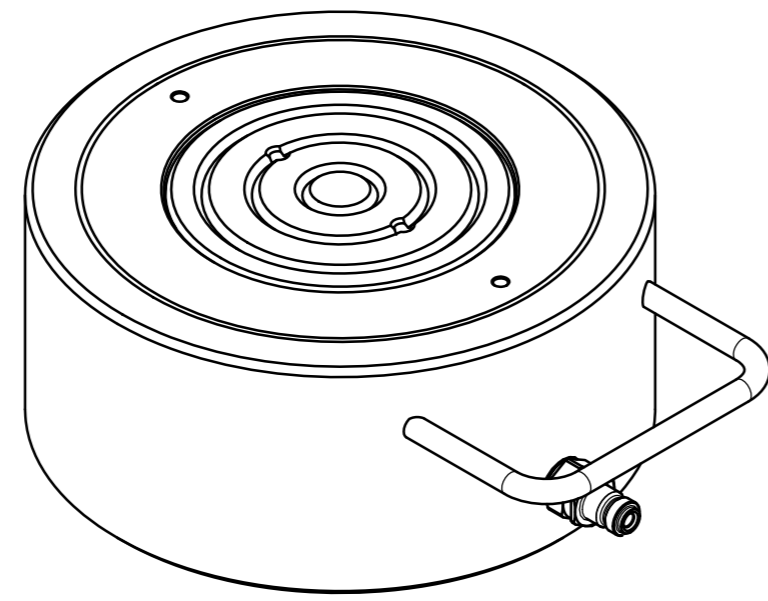

(1 : 3)

CLF670-15  
CLF1100-15  
CLF1500-15  
CLF2000-16

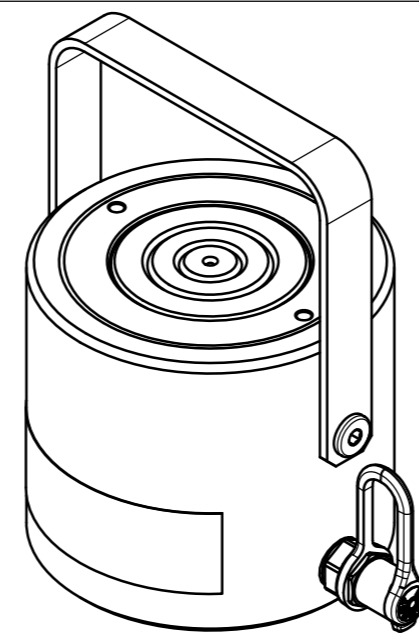

(1 : 3)

CLF670-45  
CLF1100-40

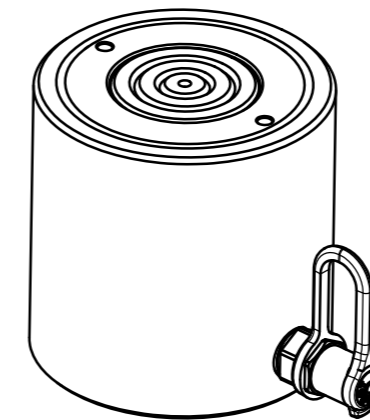

(1 : 3)

CLF450-40

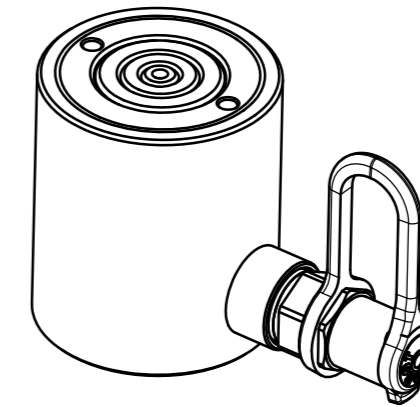

CLF110-30  
CLF220-25  
CLF220-50

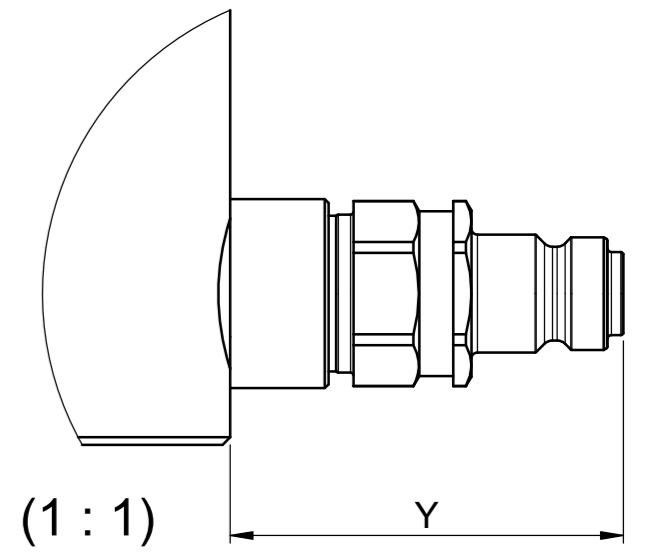

(1 : 1)

CLF110-30  
CLF220-25  
CLF220-50

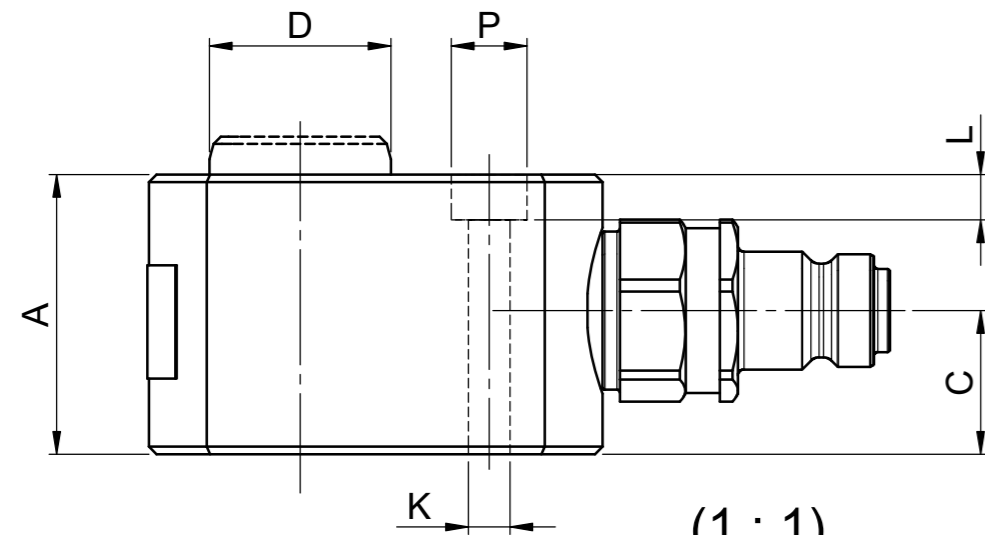

(1 : 1)

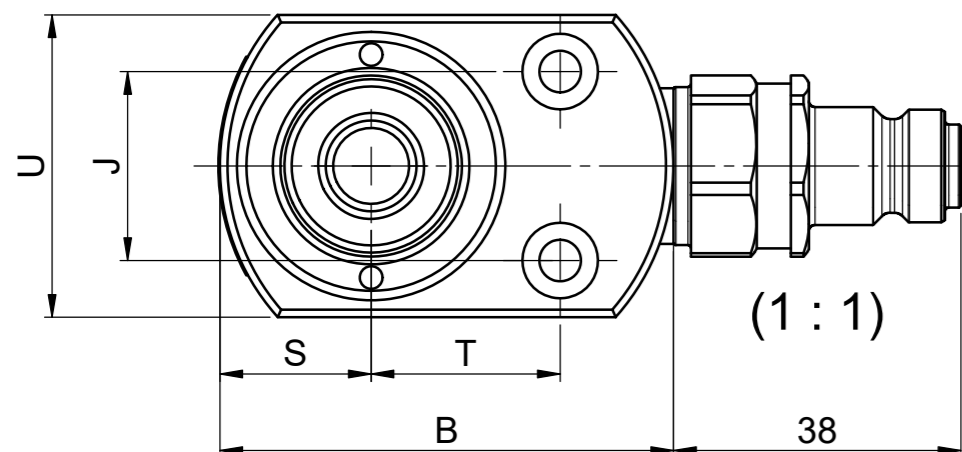

(1 : 1)

CLF50-10  
CLF110-10  
CLF220-13  
CLF450-15

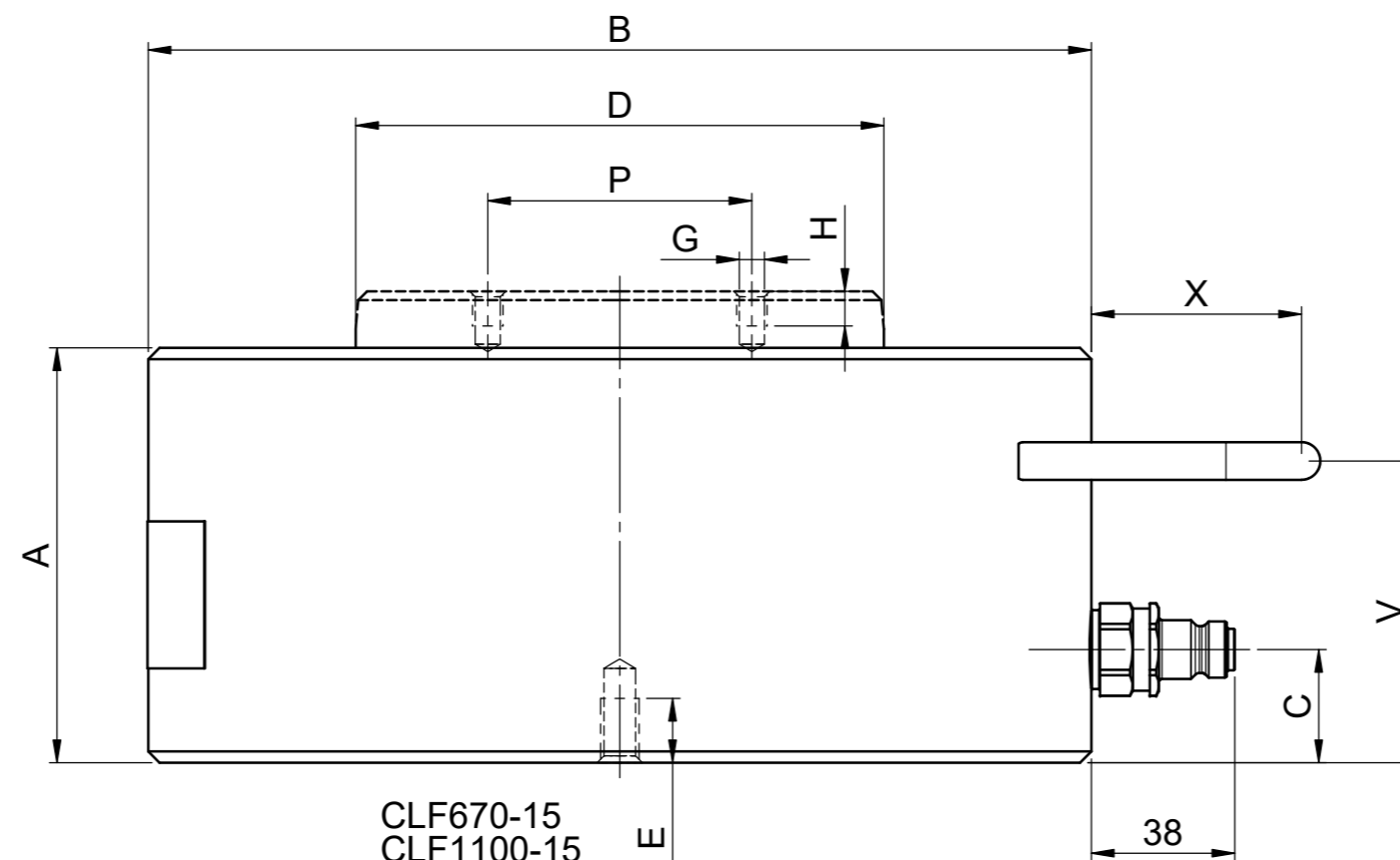

CLF670-15  
CLF1100-15  
CLF1500-15  
CLF2000-16

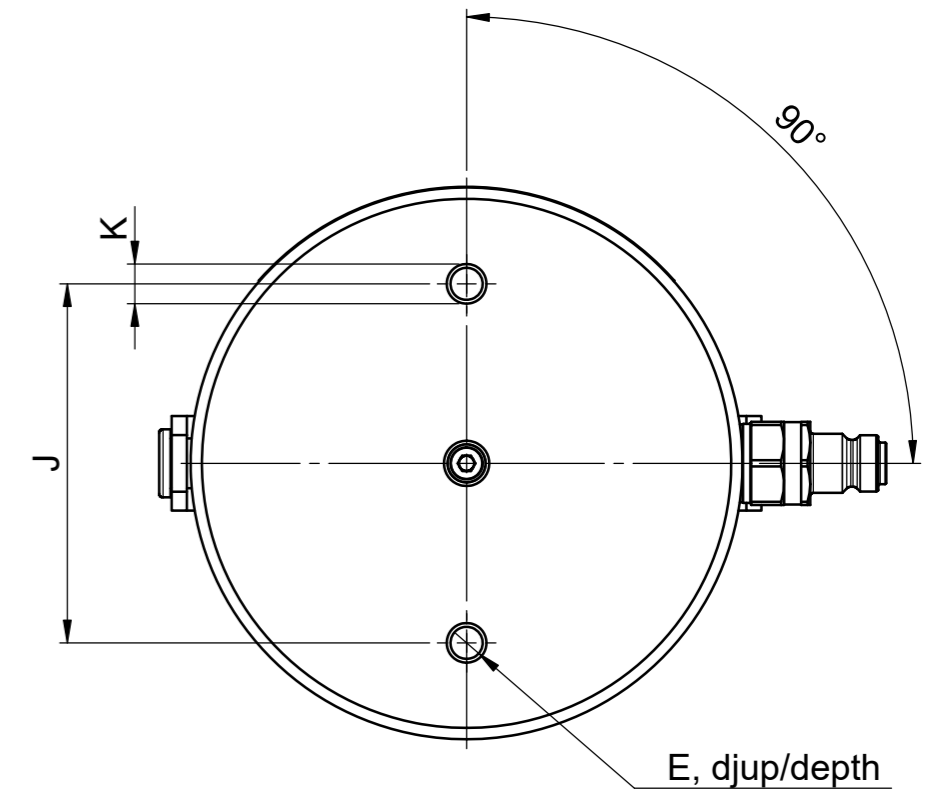

CLF450-40

CLF670-15  
CLF1100-15  
CLF1500-15  
CLF2000-16

CLF670-45  
CLF1100-40

CLF110-30  
CLF220-25  
CLF220-50

Modell (Model)	Art. nr.	Max arbetstryck, MPa (Max. pressure)	Kapacitet kN (Capacity)	Slaglängd mm (Stroke)	Kolvarean cm (Piston area)	Slagvolym cm (Stroke volume)	A mm	B $\phi$ mm	C mm	D $\phi$ mm	E mm	G	H mm	J mm	K	L mm	P $\phi$ mm	S mm	T mm	U mm	V mm	X mm	Y mm	Vikt kg (Weight)	
CLF50-10	35132	70	49	10	7,11	7,1	37	60	18	24	-	-	-	25	$\phi$ 5,5	6	10	20	25	40	-	-	-	-	0,6
CLF110-10	35133	70	111	10	15,9	15,9	43	80	18	35	-	-	-	40	$\phi$ 5,5	6	10	33	32	66	-	-	-	-	1,5
CLF220-13	35320	70	218	13,5	21,2	42,1	50	100	20	50	-	-	-	40	$\phi$ 5,5	6	10	44	41	86	-	-	-	-	2,6
CLF450-15	35305	70	445	15	6,3,6	95,4	68	134	20	60	-	-	-	67	$\phi$ 12	11	18	60	50,8	120	-	-	-	-	6,4
CLF110-30	47067	70	111	28	15,9	44,5	75	65	20	35	6	-	-	40	M6	-	-	-	-	-	-	-	-	51	1,8
CLF220-25	50450	70	218	25	32,1	78	65	96	16	50	5	-	-	55	M6	-	-	-	-	-	-	-	-	38	2,25
CLF220-50	37553	70	218	50	32,1	156	107	85	20	50	5	-	-	55	M6	-	-	-	-	-	-	-	-	51	3,9
CLF450-40	47071	70	445	40	63,6	254,4	120	120	20	60	10	-	-	75	M8	-	-	-	-	-	-	-	-	-	8,8
CLF670-15	35413	70	665	15	95	142,5	78	146	20	80	8	-	-	110	M8	-	-	-	-	-	60	45	-	-	9,2
CLF1100-15	35166	70	1078	15	154	231	90	180	20	100	10	-	-	120	M8	-	-	-	-	-	60	53	-	-	17
CLF1500-15	35485	70	1498	15	214	321	100	220	27	125	14	M8	10	150	M10	-	70	-	-	-	80	58	-	-	28
CLF2000-16	35490	70	1985	16	284	454	110	250	30	140	19	M8	10	200	M10	-	70	-	-	-	80	61	-	-	40
CLF670-45 *	47075	70	665	45	95	427,5	130	146	20	80	12	-	-	95	M10	-	-	-	-	-	85	-	-	-	14,3
CLF1100-40 *	47079	70	1078	40	154	616	140	180	25	100	18	-	-	120	M12	-	-	-	-	-	95	-	-	-	23,7

\* Levereras med bärhandtag (handtaget är löstagbart) / Delivered with handle (the handle is detachable)

Issue	Change	Position	Date	Sign.
10	Omritad, mått E & H tillkom		2017-05-19	GB1

Material	Blank, dimension	Heat treatment	Surface treatment
Permissible deviations for dimensions without indication of tolerances		Surface roughness unless specified	
Machined parts acc.SS-ISO-2768-1	Castings acc.SS-ISO-8062	Fuse welded constr. acc.SS-EN ISO 13920	$\checkmark$ Ra $\mu$ m
Designed by	Drawn by	Date	Product
Prod. appr.	Design appr.	Scale	<b>MÄTTRITNING</b> <b>DIMENSIONAL DRAWING</b>
2016-10-24	2016-10-21	1:2	Title
<b>REHOBOT</b>			CLF - CYLINDRAR CLF - CYLINDERS
			Replaces C-35613, C-35614
			Replaced by <b>B-35613</b>