

DENNA RITNING ÄR REHOBOT AB:s EGENDOM. SKYDDAD ENLIGT GÄLLANDE LAG. THIS DRAWING IS THE PROPERTY OF REHOBOT AB. PROTECTED BY PREVAILING LAW.

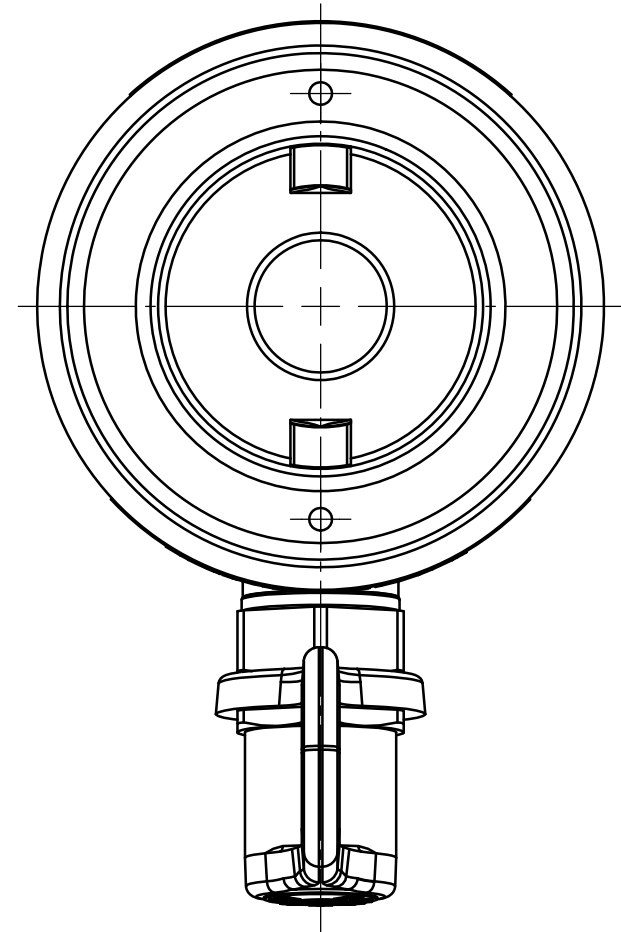
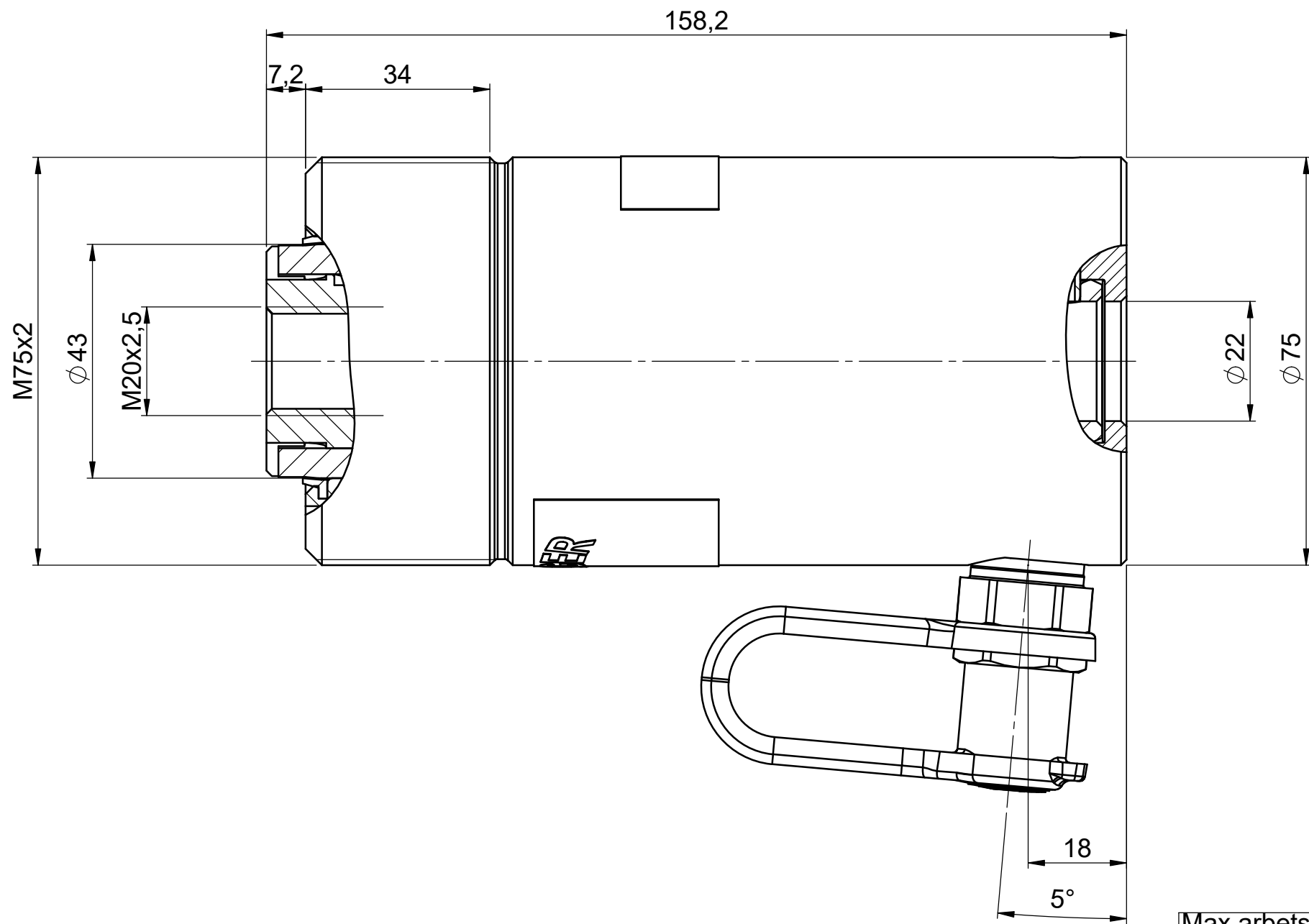

Max arbetstryck Max working pressure	70 MPa
Kapacitet / Capacity	148 kN
Slaglängd / Stroke	50 mm
Kolvarea / Piston area	21,2 cm <sup>2</sup>
Slagvolym / Stroke volume	106 cm <sup>3</sup>
Vikt / Weight	4 kg

Material		Blank, dimension		Heat treatment		Surface treatment	
Machined parts acc.SS-ISO-2768-1		Castings acc.SS-ISO-8062		Fuse welded constr. acc.SS-EN ISO 13920		Surface roughness unless specified	
Designed by <b>AN1</b>	Drawn by <b>AN1</b>	Date 2013-10-30	Product <b>CHF15-51</b>		Tol.system acc. ISO		
Prod.appr. RJ 2017-09-21	Design appr. CS 2017-09-21	Scale 1:1	Title <b>MÅTTRITNING DIMENSIONED DRAWING</b>		Replaces		
				Replaced by		<b>C-50711</b>	

Issue	Change	Position	Date	Sign.
1	Omritad		2017-09-20	GB

8

7

6

5

4

3

2

1

1

A

B

C

D

E

F